

DC - 20 GHz Discrete power pHEMT

TGF2022-12



Product Description

The TriQuint TGF2022-12 is a discrete 1.2 mm pHEMT which operates from DC-20 GHz. The TGF2022-12 is designed using TriQuint's proven standard 0.35µm power pHEMT production process.

The TGF2022-12 typically provides > 31 dBm of saturated output power with power gain of 13 dB. The maximum power added efficiency is 58% which makes the TGF2022-12 appropriate for high efficiency applications.

The TGF2022-12 is also ideally suited for Point-to-point Radio, High-reliability space, and Military applications.

The TGF2022-12 has a protective surface passivation layer providing environmental robustness.

Lead-free and RoHS compliant

Key Features and Performance

- Frequency Range: DC - 20 GHz
- > 31 dBm Nominal Psat
- 58% Maximum PAE
- 39 dBm Nominal OIP3
- 13 dB Nominal Power Gain
- Suitable for high reliability applications
- 1.2mm x 0.35µm Power pHEMT
- Nominal Bias Vd = 8-12V, Idq = 90-150mA (Under RF Drive, Id rises from 90mA to 300mA)
- Chip Dimensions: 0.57 x 0.79 x 0.10 mm (0.022 x 0.031 x 0.004 in)

Primary Applications

- Point-to-point Radio
- High-reliability space
- Military
- Base Stations
- Broadband Wireless Applications

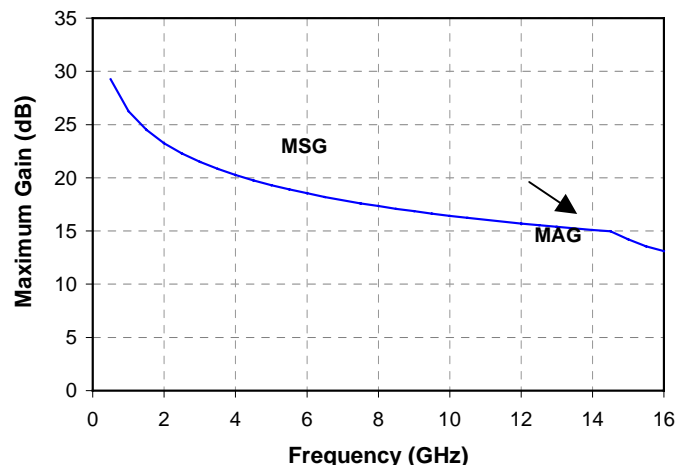

Note: This device is early in the characterization process prior to finalizing all electrical specifications. Specifications are subject to change without notice.

**TABLE I
MAXIMUM RATINGS**

TGF2022-12

Symbol	Parameter <u>1/</u>	Value	Notes
V ⁺	Positive Supply Voltage	12.5 V	<u>2/</u>
V ⁻	Negative Supply Voltage Range	-5V to 0V	
I ⁺	Positive Supply Current	564 mA	<u>2/</u>
I _G	Gate Supply Current	14 mA	
P _{IN}	Input Continuous Wave Power	26 dBm	<u>2/</u>
P _D	Power Dissipation	See note 3	<u>2/ 3/</u>
T _{CH}	Operating Channel Temperature	150 °C	<u>4/</u>
T _M	Mounting Temperature (30 Seconds)	320 °C	
T _{STG}	Storage Temperature	-65 to 150 °C	

- 1/ These ratings represent the maximum operable values for this device.
- 2/ Combinations of supply voltage, supply current, input power, and output power shall not exceed P_D.
- 3/ For a median life time of 1E+6 hrs, Power dissipation is limited to:

$$P_D(\text{max}) = (150\text{ °C} - T_{\text{BASE}}\text{ °C}) / 69.0\text{ (°C/W)}$$
- 4/ Junction operating temperature will directly affect the device median time to failure (T_M). For maximum life, it is recommended that junction temperatures be maintained at the lowest possible levels.

**TABLE II
DC PROBE CHARACTERISTICS
(T_A = 25 °C, Nominal)**

Symbol	Parameter	Minimum	Typical	Maximum	Unit
I _{DSS}	Saturated Drain Current	-	360	-	mA
G _m	Transconductance	-	450	-	mS
V _P	Pinch-off Voltage	-1.5	-1	-0.5	V
V _{BGS}	Breakdown Voltage Gate-Source	-30	-	-14	V
V _{BGD}	Breakdown Voltage Gate-Drain	-30	-	-14	V

Note: For TriQuint's 0.35um power pHEMT devices, RF breakdown >> DC breakdown

TABLE III
RF CHARACTERIZATION TABLE 1/
 (T_A = 25 °C, Nominal)

TGF2022-12

SYMBOL	PARAMETER	f = 10 GHz		f = 18 GHz		UNITS
		Vd = 10V Idq = 90 mA	Vd = 12V Idq = 90 mA	Vd = 10V Idq = 90 mA	Vd = 12V Idq = 90 mA	
Power Tuned:						
Psat	Saturated Output Power	31.9	32.6	31.1	31.7	dBm
PAE	Power Added Efficiency	52.4	51.9	41.5	37.0	%
Gain	Power Gain	12.9	12.9	8.3	8.0	dB
Rp <u>2/</u>	Parallel Resistance	22.34	28.49	21.77	24.22	Ω
Cp <u>2/</u>	Parallel Capacitance	0.552	0.515	0.461	0.481	pF
Γ _L <u>3/, 4/</u>	Load Reflection coefficient	0.580 ∠ 153.7	0.559 ∠ 145.4	0.693 ∠ 154.8	0.713 ∠ 153.0	-
Efficiency Tuned:						
Psat	Saturated Output Power	31.3	32.3	30.5	31.1	dBm
PAE	Power Added Efficiency	58.3	56.0	46.0	42.5	%
Gain	Power Gain	13	13	8.5	8.3	dB
Rp <u>2/</u>	Parallel Resistance	36.24	37.11	25.65	33.49	Ω
Cp <u>2/</u>	Parallel Capacitance	0.503	0.510	0.550	0.559	pF
Γ _L <u>3/, 4/</u>	Load Reflection coefficient	0.569 ∠ 137.1	0.577 ∠ 136.6	0.759 ∠ 153.5	0.795 ∠ 150.6	-
OIP3	Output TOI	40	39	40	39	dBm

1/ Values in this table are from measurements taken from a 0.6mm unit pHEMT cell at 10 and 18 GHz

2/ Large signal equivalent pHEMT output network

3/ Optimum load impedance for maximum power or maximum PAE at 10 and 18 GHz

4/ The reflection coefficients for this device have been calculated from the scaled large signal Rp & Cp. The series resistance and inductance (Rd and Ld) shown in the Figure on page 4 is excluded

TABLE IV
THERMAL INFORMATION

Parameter	Test Conditions	T _{CH} (°C)	θ _{JC} (°C/W)	T _M (HRS)
θ _{JC} Thermal Resistance (channel to backside of carrier)	Vd = 12 V Idq = 90 mA P _{diss} = 1.08 W	145	69	1.6 E+6

Note: Assumes eutectic attach using 1.5 mil 80/20 AuSn mounted to a 20 mil CuMo Carrier at 70°C baseplate temperature.

Linear Model for 0.6 mm Unit pHEMT cell

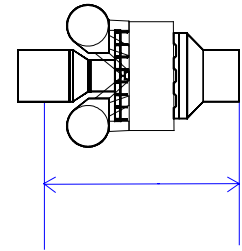
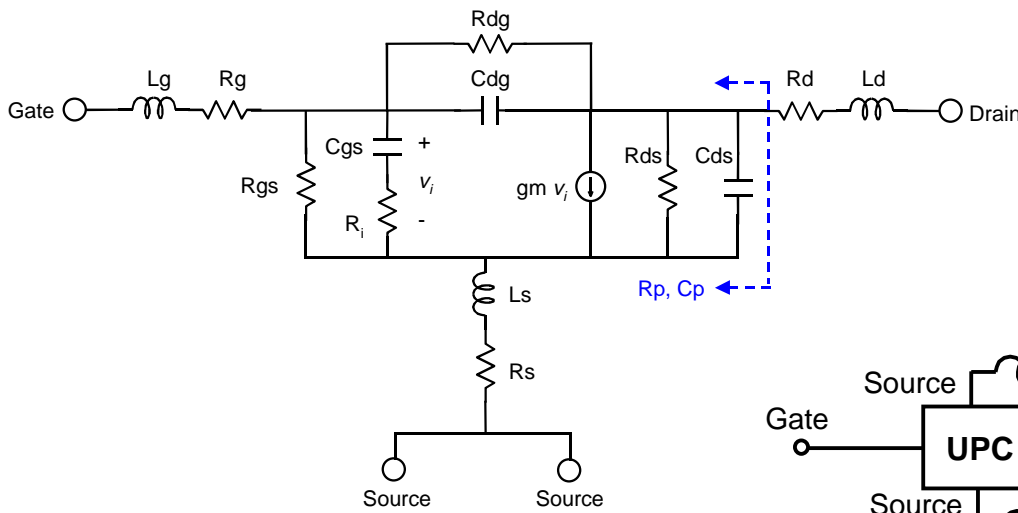

Unit pHEMT cell Reference Plane

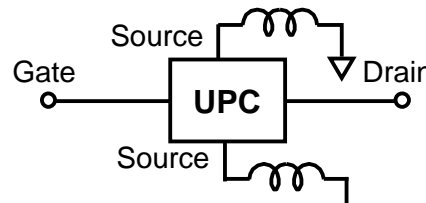

UPC = 0.6mm Unit pHEMT Cell

MODEL PARAMETER	Vd = 8V Idq = 45mA	Vd = 8V Idq = 60mA	Vd = 8V Idq = 75mA	Vd = 10V Idq = 45mA	Vd = 10V Idq = 60mA	Vd = 12V Idq = 45mA	UNITS
Rg	0.22	0.23	0.24	0.23	0.24	0.24	Ω
Rs	0.40	0.41	0.41	0.46	0.45	0.50	Ω
Rd	0.51	0.52	0.52	0.50	0.50	0.48	Ω
gm	0.195	0.202	0.202	0.188	0.195	0.183	S
Cgs	1.50	1.63	1.70	1.64	1.73	1.71	pF
Ri	1.65	1.59	1.58	1.72	1.64	1.73	Ω
Cds	0.115	0.115	0.116	0.114	0.115	0.114	pF
Rds	243.14	247.08	255.12	278.72	279.31	302.49	Ω
Cgd	0.072	0.066	0.063	0.064	0.061	0.060	pF
Tau	5.94	6.23	6.51	6.85	6.95	7.36	pS
Ls	0.001	0.001	0.001	0.001	0.001	0.001	nH
Lg	0.108	0.108	0.108	0.108	0.108	0.108	nH
Ld	0.121	0.120	0.118	0.118	0.118	0.117	nH
Rgs	5110	5140	8310	5110	5420	5120	Ω
Rgd	57700	64800	74400	79400	82900	82300	Ω

Linear Model for 1.2mm pHEMT

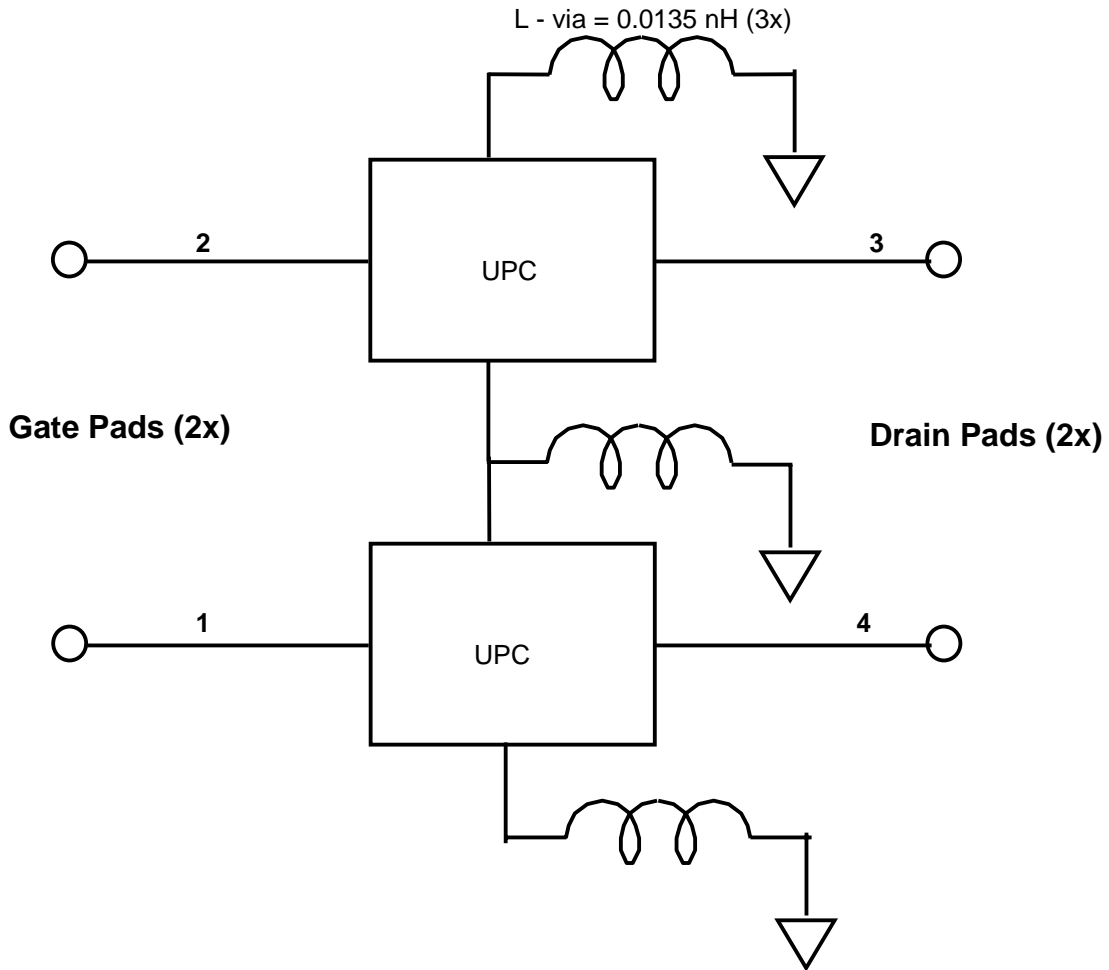

Unmatched S-parameters for 1.2 mm pHEMT

Bias Conditions: Vd = 12V, Idq = 90mA

Frequency (GHz)	s11 dB	s11 ang deg	s21 dB	s21 ang deg	s12 dB	s12 ang deg	s22 dB	s22 ang deg
0.5	-0.449	-74.97	25.960	139.64	-32.579	51.44	-7.225	-40.59
1	-0.566	-114.01	22.665	117.83	-29.857	31.56	-9.792	-62.45
1.5	-0.616	-133.49	19.905	105.89	-29.100	21.51	-11.461	-74.20
2	-0.638	-144.62	17.702	98.10	-28.810	15.62	-12.337	-81.55
2.5	-0.648	-151.74	15.902	92.30	-28.680	11.71	-12.687	-86.71
3	-0.654	-156.68	14.390	87.57	-28.620	8.88	-12.706	-90.67
3.5	-0.657	-160.33	13.087	83.49	-28.595	6.69	-12.526	-93.91
4	-0.658	-163.15	11.945	79.82	-28.592	4.91	-12.225	-96.68
4.5	-0.658	-165.41	10.926	76.44	-28.603	3.43	-11.858	-99.15
5	-0.658	-167.26	10.008	73.26	-28.624	2.15	-11.454	-101.40
5.5	-0.657	-168.83	9.170	70.24	-28.652	1.03	-11.036	-103.51
6	-0.655	-170.17	8.400	67.34	-28.687	0.03	-10.615	-105.49
6.5	-0.654	-171.35	7.687	64.53	-28.728	-0.87	-10.200	-107.39
7	-0.652	-172.39	7.022	61.80	-28.773	-1.69	-9.795	-109.22
7.5	-0.650	-173.32	6.398	59.14	-28.822	-2.44	-9.403	-110.99
8	-0.647	-174.17	5.811	56.53	-28.875	-3.13	-9.025	-112.72
8.5	-0.645	-174.94	5.256	53.97	-28.931	-3.76	-8.663	-114.40
9	-0.642	-175.66	4.729	51.46	-28.991	-4.35	-8.316	-116.05
9.5	-0.639	-176.32	4.227	48.99	-29.053	-4.89	-7.985	-117.66
10	-0.636	-176.94	3.747	46.56	-29.118	-5.38	-7.669	-119.25
10.5	-0.633	-177.53	3.288	44.16	-29.185	-5.84	-7.367	-120.81
11	-0.630	-178.08	2.847	41.79	-29.255	-6.26	-7.079	-122.34
11.5	-0.627	-178.61	2.423	39.45	-29.326	-6.65	-6.805	-123.84
12	-0.624	-179.11	2.014	37.14	-29.400	-7.00	-6.543	-125.33
12.5	-0.621	-179.60	1.619	34.86	-29.475	-7.31	-6.293	-126.79
13	-0.618	-179.94	1.237	32.61	-29.551	-7.59	-6.055	-128.23
13.5	-0.614	-179.49	0.867	30.38	-29.628	-7.85	-5.828	-129.65
14	-0.611	-179.05	0.508	28.17	-29.707	-8.06	-5.611	-131.04
14.5	-0.608	-178.63	0.160	25.99	-29.786	-8.25	-5.404	-132.42
15	-0.604	-178.22	-0.180	23.83	-29.866	-8.41	-5.206	-133.78
15.5	-0.601	-177.82	-0.510	21.70	-29.947	-8.54	-5.017	-135.12
16	-0.598	-177.43	-0.831	19.59	-30.028	-8.64	-4.836	-136.44
16.5	-0.594	-177.05	-1.145	17.49	-30.108	-8.71	-4.663	-137.75
17	-0.591	-176.68	-1.452	15.42	-30.189	-8.75	-4.497	-139.03
17.5	-0.588	-176.31	-1.751	13.37	-30.270	-8.76	-4.339	-140.30
18	-0.584	-175.95	-2.044	11.34	-30.350	-8.75	-4.187	-141.55
18.5	-0.581	-175.60	-2.330	9.33	-30.430	-8.71	-4.041	-142.79
19	-0.578	-175.25	-2.611	7.33	-30.509	-8.65	-3.901	-144.01
19.5	-0.575	-174.90	-2.886	5.36	-30.588	-8.56	-3.768	-145.21
20	-0.572	-174.56	-3.156	3.40	-30.665	-8.44	-3.639	-146.40
20.5	-0.569	-174.23	-3.421	1.46	-30.741	-8.30	-3.516	-147.57
21	-0.566	-173.90	-3.681	-0.47	-30.816	-8.14	-3.397	-148.72
21.5	-0.563	-173.57	-3.936	-2.38	-30.889	-7.95	-3.283	-149.87
22	-0.560	-173.24	-4.187	-4.27	-30.961	-7.75	-3.174	-150.99
22.5	-0.557	-172.92	-4.434	-6.15	-31.031	-7.52	-3.068	-152.11
23	-0.554	-172.60	-4.677	-8.01	-31.099	-7.26	-2.967	-153.21
23.5	-0.551	-172.29	-4.917	-9.86	-31.166	-6.99	-2.869	-154.30
24	-0.548	-171.98	-5.153	-11.70	-31.230	-6.70	-2.775	-155.37
24.5	-0.545	-171.67	-5.385	-13.52	-31.292	-6.40	-2.685	-156.43
25	-0.542	-171.36	-5.614	-15.33	-31.352	-6.07	-2.597	-157.48
25.5	-0.540	-171.05	-5.841	-17.12	-31.410	-5.73	-2.513	-158.51
26	-0.537	-170.75	-6.064	-18.91	-31.465	-5.37	-2.432	-159.54

Note: The s-parameters are calculated by connecting nodes 1-2 together, and nodes 3-4 together to form a 2-port network.

Mechanical Drawing

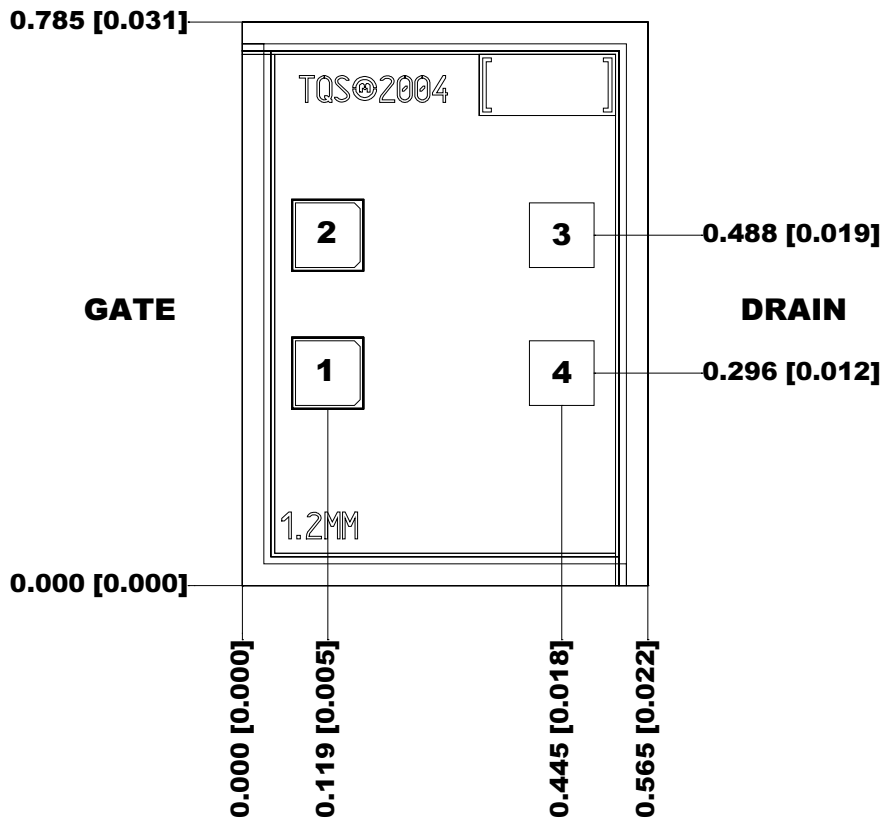

Units: millimeters (inches)

Thickness: 0.100 (0.004)

Chip edge to bond pad dimensions are shown to center of bond pad

Chip size tolerance: +/- 0.051 (0.002)

GND IS BACKSIDE OF MMIC

Bond pads #1-2: (Gate) 0.090 x 0.090 (0.004 x 0.004)

Bond pads #3-4: (Drain) 0.090 x 0.090 (0.004 x 0.004)

GaAs MMIC devices are susceptible to damage from Electrostatic Discharge. Proper precautions should be observed during handling, assembly and test.

Assembly Process Notes

Reflow process assembly notes:

- Use AuSn (80/20) solder with limited exposure to temperatures at or above 300 °C for 30 sec
- An alloy station or conveyor furnace with reducing atmosphere should be used.
- No fluxes should be utilized.
- Coefficient of thermal expansion matching is critical for long-term reliability.
- Devices must be stored in a dry nitrogen atmosphere.

Component placement and adhesive attachment assembly notes:

- Vacuum pencils and/or vacuum collets are the preferred method of pick up.
- Air bridges must be avoided during placement.
- The force impact is critical during auto placement.
- Organic attachment can be used in low-power applications.
- Curing should be done in a convection oven; proper exhaust is a safety concern.
- Microwave or radiant curing should not be used because of differential heating.
- Coefficient of thermal expansion matching is critical.

Interconnect process assembly notes:

- Thermosonic ball bonding is the preferred interconnect technique.
- Force, time, and ultrasonics are critical parameters.
- Aluminum wire should not be used.
- Devices with small pad sizes should be bonded with 0.0007-inch wire.
- Maximum stage temperature is 200 °C.